



ORACLE

Journal of the Institute of Sheet Metal Engineering



**Notice of AGM and
Gold Medal Dinner**

Page 6

**Success of
LoCoLite**

Page 16

**The World's Largest
Servo Press**

Page 22

Principal Officers

President

Mr Alan Shaw



Chairman of Council

Mr Steve Morley



Honorary Treasurer

Mrs Josie Stevenson



Honorary Secretary

Mr Bill Pinfold

Telephone: 07891 499146

Email: ismesec@gmail.com



Events Officer

Mr Adrian Nicklin

Telephone: 07774 260126

Email: adriannicklin@btinternet.com



Advertising Manager

Ray Jelf

Telephone: 01608 730994

Email: rayjelf@mma.org.uk



The Oracle published in association with the Metalforming Machinery Makers Association Ltd. ISME & MMMA working together for the benefit of the Sheet Metalforming Industry

www.isme.org.uk

www.mmma.org.uk

Contents

From the President. 5

Secretary's Report. 6

ISME at Thinktank "Meet the Experts Day" February 2017. 8

"The State of Engineering" 10

ISME Chairman appointed Sertec Group Engineering Director. 12

WORLIFTSDelivers Enerpac Hydraulic Tool Safety Presentation. 12

Launch of Nukon Fiber Laser Cutting Machines into UK 14

Punch Tooling with 9mm Grind Life. 14

Success of LoCoLite 16

CBM's trail-blazing training project moves ever closer. 18

Report on CBM Health & Safety Meeting 19

Baxi chooses AP&T 20

The World's largest Servo Press 22

ISME Sheet Metal Technology Competition 24

Cover picture: Success of LoCoLite

The Oracle, mouthpiece of the Institute, speaks for and to the world of Sheet Metal Forming & Pressworking by way of featuring News, Views and Topics around the Industry

New Roemheld compact hydraulic sliding clamp



Roemheld has introduced a range of compact, hydraulic sliding clamps designed for clamping in tight spaces on systems, press beds and rams. The new "compact" version provides the same clamping force as the "classic" sliding clamp, but both the size and the weight have been reduced. The new Roemheld compact sliding clamp is ideally suited for retrofitting without the need for standardisation of the width and depth of the dies.

Roemheld workholding. The one to watch.

For full details contact us on 01462 459052
or visit www.roemheld.co.uk



ROEMHELD
HILMA ■ STARK

Scan code to
download our
new App.



From the President

Dear ISME Members,

You will probably be mightily relieved to learn that apart from this one instance, the word "Brexit" will not appear again in my President's Notes for this edition of the Oracle.

Instead my attention has been drawn to the subject of Apprenticeships, which could be either another example of Government "qualified" policy success or continuing failure depending on your viewpoint. In a recent BBC on-line news report the Government announced its' aim to increase apprentice numbers dramatically over the next few years, an initiative to be funded in part by larger employers (those with a pay bill of over £3M P/A) paying a levy.

There certainly seems to be some justification in renewed effort on this front, since despite the initiatives of the last few years, we in the UK still lag well behind many of our World competitor nations in the provision and take up of apprenticeships. The latest statistics suggest about 20 apprentices per 1000 of the working population in the UK, whereas in Germany the figure is nearer 40. Government statistics also reveal that only around 25% of new apprentices are aged 19 or under, and that the numbers taking up Engineering and Manufacturing are dwarfed by those opting for the Business Administration, Law, Health, Public Services, Retail sectors.

With the Elite Centre for Manufacturing Skills (ECMS) due to open later this year, we in the Metal Forming sector will at last get a resource appropriate to our needs, and hopefully one where quality of learning will be paramount. A great deal of credit must go to our Events Officer, Adrian Nicklin, who has been a champion of this initiative from the outset, and I would urge all members to look at making use of the facility when it comes on line.

Alan Shaw - President



ISME Honorary Secretary's Report



I'm pleased to report on a positive few months for the Institute. You will read elsewhere of the successful Thinktank event in February and tickets for the AGM and Gold Medal Dinner in May are selling well. The exciting venue of the Coventry Motor Museum has already attracted several entries for the Skills Competition in June.

We would like to feature more stories about members and their companies. If you have a good news story about investment, people or large contracts you would like mentioning in Oracle, please let me know. We are always looking for interesting works visits. If you would like to host a tour of your company, again get in touch.

Contact Details

We are finding that an increasing number of our emails publicising events are bouncing back. If you have a new email address please make sure you inform us at ismesec@gmail.com and similarly if you move home.

We are pleased to announce a new Company Member, Power Press Manufacturer Nidec-Minster.

A profile of Nidec-Minster appears elsewhere in Oracle

We regret to report that Honorary ISME member William Shields of Kenilworth has passed away. William worked at Dunlop Rim and Wheel and was Chairman of the ISME Coventry branch in the 1970s.

Bill Pinfold - ISME Hon Secretary

Notice of the Institute of Sheet Metal Engineering 2017 AGM & Gold Medal Dinner

72nd ANNUAL GENERAL MEETING

will be held on Thursday 11th May 2017 at 6.45 pm prompt
followed at 7.30pm by the

Gold Medal Dinner

The 2017 Gold Medal is being presented to
Mark White

Former Chief Technical Specialist for Lightweight Structures at Jaguar Land Rover

Aston Wood Golf Club, Blake Street. Sutton Coldfield B74 4EU

Copies of the agenda and minutes of last year's meeting can be obtained from
the Honorary Secretary ismesec@gmail.com

YEAR OF
INNOVATION

New Generation Automation BY AP&T



20% higher acceleration,
20% lower weight and 10%
lower energy consumption.

APT
&
AUTOMATION · PRESSES · TOOLING
APTGROUP.COM



ISME at Thinktank “Meet the Experts Day” February 2017

Each half term the Thinktank in the Birmingham Museum, Millennium point hold a Meet the Experts Day where large companies and Institutions are invited to put on an exhibition with an intent to engage young people into engineering and in STEM subjects generally. The format is for engineers to show various aspects of engineering basically from their own work experience. This is often in the form of interactive activities. Companies are encouraged to bring along various examples of engineering parts and be prepared to talk about these and how they are used within their industry. Parts which the children can “play” with – dismantle – build – explore – etc. are particularly welcome.

ISME were represented by Sertec, with Open Class entries from previous ISME Skills Competitions supplied by Babcock Engineering and model maker and engineer Alec James.

On the Sertec stand toolmaker apprentices Matthew Murchington and Austin Forletta showed their work pieces from last year’s ISME Skills Competition and components made by Sertec for JLR. They talked to the visitors about the opportunities in

engineering sharing their own experiences as apprentice toolmakers.

ISME’s good friend, Alec James with his colleague Chris, again showed some of the excellent models he has built including a rotary engine, radial engine and a Congreve Ball clock. Watching the rolling ball fascinated children and parents alike.

The Thinktank is always busy at half term but the event was held on the Friday after storm Doris and footfall in the Thinktank was down on previous years as parents took advantage on the sunny weather to visit outdoor events. However, the number visiting the ISME stand was up with parents and young people taking a particular interest in the Wolf’s Head, Eagle and Spitfire produced by the craftsmen at Babcock

The Institute was supported on the day by Adrian Nicklin and Bill Pinfold and our thanks also go to Steve Morley and Judith Bagley of Sertec for supplying the stand and letting their staff take part.

A long day but very rewarding and hopefully we will do it again next year with an even bigger and better display.



**Press Load Monitoring
Process Monitoring
Production Recording
Calibration Services
Bespoke Solutions**



Decade Monitoring Solutions Ltd
+44 (0)121 359 3978
www.decade.co.uk



“The State of Engineering”

Points taken from Engineering UK 2017

- Engineering contributes 26% of the UK's GDP – viewed in terms of Gross Value Added, its contribution is more than that of the retail and wholesale and financial and insurance sectors combined
- Engineering activity has a particularly high wider employment multiplier effect: every extra person employed in engineering supports another 1.74 other jobs
- 9% more engineering and technology first degrees obtained in 2014/15 than the year before
- Highest number of engineering related apprenticeship starts in England for ten years
- More 11-16 year olds “would consider a career in engineering” (up from 40% to 51% in four years).
- Engineering graduate supply falls well short of demand: we conclude from the report, a shortfall of at least 20,000 annually (and likely higher, depending on assumptions)
- We are highly dependent on attracting and retaining international talent from the EU and beyond to help meet this shortfall: a vital part of post-Brexit policies
- UK postgraduate engineering and technology degrees are successful internationally, but the proportion of UK-domiciled graduates is becoming too low to be sustainable in the long-term (down to 25% of taught engineering and technology postgraduate qualifications, in 2014/15)
- Efforts to attract girls and women into engineering are falling short: today less than 1 in 8 of the engineering workforce is female; boys are 3.5 times more likely to study A level Physics (in England, Wales and Northern Ireland) than girls; and five times more likely to gain an engineering and technology degree.

Recommendations

Several recommendations have been developed to tackle these problems:-

1. Encourage many more pupils to choose STEM subjects and make well-informed choices that maintain the option of a career in engineering and technology
2. Increase diversity in engineering and technology, through the entire education system and into and throughout employment
3. Draw on the talent already in the workforce: increase the skills, and improve the retention, of existing engineering employees – and attract employees from other sectors
4. Enhance the vital international dimension in UK Higher Education: world-class, welcoming and open for study – and subsequent employment
5. Develop an industrial strategy that reinforces and sustains engineering's contributions to the UK, and that recognises and helps to address the STEM skills gap.

Some Statistics

- 80% of engineering enterprises have four or fewer employees
- 52% of employees work in an enterprise with 100 or more people
- 42% of employees work in an enterprise with 250 or more people
- £486 billion contributed by engineering to UK GDP in 2015
- 7% rise (to 650,000) in 2015 in the number of UK engineering enterprises
- 5.7 million employees work in registered engineering enterprises in the UK – 19% of total UK employment

If any member wishes to see a full copy of the 235 page report in PDF please contact the Hon. Secretary at ismesec@gmail.com

T.M.A.
presses

NEW POWER PRESSES



- From 6-2,000 tons
- World Precise Machinery Group power presses
- Non-standard strokes available
- Latest technology wet multi-plate clutch/brake
- Hydraulic overload protection
- TMA designed electrical control circuit for complete support
- Pilz PNOZ Safety PLC
- Pilz light guards (option)
- Automatic lubrication
- CE marked
- Warranty and support by TMA



- Electronic servo roll feed
- Up to 24in wide material
- User-friendly touch screen display
- Pilot release
- Handheld remote jog station
- Pneumatic roll pressure
- Designed, built, programmed and fully supported by TMA

TMA are the UK's largest independent power press service and repair company

Contact us for all your power press requirements

- Sales • Service
- Spares • Repairs
- Maintenance

+44 (0)121 328 1908

TMA Engineering Ltd, 95-111 Tyburn Road Erdington Birmingham B24 8NQ UK
Tel +44 (0)121 328 1908 Fax: +44 (0)121 322 2017
www.TMApresses.com info@TMApresses.com

T.M.A.
ENGINEERING LTD
Est. 1973

ISME Chairman appointed Sertec Group Engineering Director



As Sertec continues to evolve and develop its management structures to support the burgeoning business activity throughout the Group, The Company has announced two key appointments from within, to build on its continuing growth.

With immediate effect, Steve Morley is promoted to Group Engineering Director.

After twenty-one years of loyal service with Sertec, Steve Morley's new role is testament to his hard work and determination.

Steve has developed a new Group structure to support both current and emerging business opportunities, through which it will drive and deliver new projects, engineering expertise and future technologies.

This structure successfully integrates the recently acquired Wild management personnel

with the Sertec teams and as it matures, it will support The Group in delivering an improved portfolio of product expertise to a broader customer base.

Mr Morley has driven Sertec's research and development into lightweight weld technologies (in collaboration with Jaguar Land Rover and Warwick University) and his development as Director in charge of Group Projects has been rewarded with his appointment to the new role of Engineering Director.

Group Quality and Projects Director Peter Pugh, said "This is a positive step for both the Sertec Group and in particular Steve, who is a dedicated and committed individual who has been a key member of the Board in supporting Sertec's success to date."

WORLIFTS Delivers Enerpac Hydraulic Tool Safety Presentation

As part of ongoing training at Worklifts, the company arranged for a representative from Enerpac to give a safety presentation to its employees.

The Instructor displayed true working knowledge and experience of the products, which he imparted to the maintenance team in attendance. This initiative increased the technicians' knowledge of the safe and correct use of hydraulic tools and associated equipment.

The product and safety information has been a catalyst for the team to improve and check their hydraulic equipment on a more regular basis. Old hoses have already replaced as a result and pressure gauges fitted to all hand pumps.

This was simple but obvious advice; the Technician's now know what force is being applied during operation, so if a task is not accomplished when the equipment has reached 80% of its full force capacity, the process is stopped and the method is reappraised, thus avoiding accident or damage to the equipment.



World class supplier of lightweight stampings, assembled components...

...and so much more. Through investment in a brand new £16m press shop and the recent acquisition of a £50m business, Sertec now provides an even more comprehensive portfolio of manufacturing expertise, to world class automotive customers.

Steel and aluminium stamping, robotic welding and manual assemblies, hinges & closures, tubular assemblies, precision washers, fine blanking, spring and wire forming.



PROUD



Launch of Nukon Fiber Laser Cutting Machines into UK

MTL Engineering, well known for repair, servicing and sales of CNC sheet metal machines has launched Nukon to bring the new fiber laser cutting technology to the UK.

The Nukon laser machines are already well known in Europe and the U.S. for their speed, flexibility and cost effectiveness and are now available and fully supported in the UK.

'If you are looking for a new machine we would welcome the opportunity to show you the Nukon Eco series in action. The machine offers fast cutting speed and low maintenance costs, machine controlled dynamic focus adjustment,

IPG laser source, Highyag cutting head. It has the advantage of taking minimal floor space due to its side loading design at a very competitive prices.' says Managing Director Mark Lewis.

With so much interest in the Nukon machines interested customers are visiting Nukon Europe and its manufacturing facility to see them in action.

If you are interested in finding out more about the machines please contact Mark Lewis or Howard Hayward at Nukon on 01562 744 873 or visit www.nukon.co.uk

Punch Tooling with 9mm Grind Life

MTL Engineering, well known for repair, servicing and sales of CNC sheet fabrication machinery are now exclusive UK suppliers for PASS Stanztechnik AG punch press tooling.

PASS AG is one of the largest punching tool manufacturers and a world leading company in special solutions of CNC punching tools.

The H-PM punch tool is one such punch tools which is being offered by MTL Engineering. A major feature is its 9mm grind life as it is made from a powdered tool steel. This gives a longer life between regrinds and gives increased performance.' says Managing Director, Mark Lewis.

PASS offers the options of various coatings for different punching material conditions to give their tools even more longevity.

If you would like to find out more call MTL Engineering on 01562 744 873 or visit www.mtlengineering.co.uk



BRUDERER+

We supply a full range of new & pre-owned high speed presses

Not only do we supply new and refurbished high speed presses, but also the 'best of the rest' with regards to press shop equipment and precision tooling components for press & plastic mould tools



○ New BSTA 410



○ Pre-owned BSTA 25H



○ Pre-owned BSTA 30

ONE NAME - A MULTITUDE OF POSSIBILITIES



FIBRO



○ Tooling and gas springs for press and plastic mould tools



○ State of the art Servo Feeds



BRUDERER UK LTD | Cradock Road, Luton LU4 0JF

Tel: 01582 560300 | Fax: 01582 570611 | Email: mail@bruderer.co.uk | Twitter: [@Brudereruk](https://twitter.com/Brudereruk)

www.bruderer.co.uk

Success of LoCoLite

EU FP7 Project on Cost Effective Forming of Lightweight Complex Structures

1. The Project

The prestigious €6m 3-year European research project "LoCoLite", led by Imperial College London, aimed to develop an industrially based, validated mass production system, which employs the patented, laboratory proven HFQ® (solution Heat treatment, cold-die Forming and Quenching) aluminium alloy processing technology for low cost forming of lightweight panel components with hitherto unattainable high-strength and shape complexity, for body structures of automobiles, trains and aircrafts.

It has been recently completed with tremendous success, which led to another 3-year European research project (€8m) for commercialisation of HFQ® with further cost reduction. Through the development, components produced using HFQ® are already receiving industry recognition.

2. Consortium

The LoCoLite consortium involves 16 companies and research institutes from 8 European countries.



Fig2 Lotus Door Inner, HFQ® formed at AP&T.

3. Technological Highlights

The Lotus Door Inner, Fig 2, formed from high strength AA6082 was one of the most complex automotive components formed using HFQ®. An AA6082 inner panel not only increases the strength, it also enables recycling of the whole door back into a high value AA6xxx alloy without costly disassembly of the door skin from its casing. This mono alloy approach and HFQ® have also enabled part consolidation.

Fig 3 shows another example of HFQ® in forming complex-shaped parts, Fiat B-Pillar. As a safety critical component, the strength is critically important. This part was successfully and repeatedly formed from both AA6082 and AA7075. The ultra-high strength aluminium alloy AA7075 can reach more than 500MPa UTS after artificial ageing.



Fig3 Fiat B-Pillars, HFQ® formed at AP&T.



Fig4 HAI Armrest, HFQ® formed at PAB.

The focus of the first HFQ® aircraft components is an interior component, seat armrest, in Fig 4. Despite high draw depth, steep draft angle and tight bend radii, it was successfully formed from both AA6082 and AA7075 through the HFQ® process. High strength aluminium alloys offer significant weight savings, which can be translated into increased payload and reduced fuel consumption. Understandably, this new demonstration of HFQ® technology has generated a lot of interests from the aerospace industry.



4. Opening of the new HFQ® pressing line

Impression Technologies Ltd's (ITL) new facility was officially opened, in Oct 2016, by Lord Digby Jones and Councillor Lindsley Harvard, the Lord Mayor of Coventry. The world's first HFQ® press has been installed and commissioned at a new factory, CIPCO, in Coventry. Councillor Harvard said: "It's fantastic to see this new technology ... bringing business, skilled jobs and technology to Coventry."

Jonathan Watkins, Chief Executive of ITL, said: "We have a unique technology that addresses the economical, technical and environmental needs of the huge automotive, aerospace and rail sectors; HFQ® has the potential to generate significant earnings from strategic and rapidly-growing global markets."

Matt Mead, Chief Investment Officer Mercia

Technologies plc, said: "We would like to congratulate the company on the launch of its new facilities, which we believe perfectly demonstrates the manufacturing potential... in the Midlands."

Robert Bahns, Director Technology Ventures at Imperial Innovations plc, said: "This facility will position the company ... as a technology provider that can reduce the weight and cost of components across a range of transport sectors."

Neale Ryan, Innovate UK Portfolio Manager for Low Carbon Vehicles, said: "Innovate UK is proud of its ongoing support for the company and we look forward to their continued growth."

5. Summary

The success of the LoCoLite project enables the replacement of steel with high strength aluminium for body and chassis structures of passenger cars using the low-cost HFQ® technology. This aluminium alloy processing technology, HFQ®, will be exploited in Class C and D vehicles which will cover 50% of passenger cars produced in the world. This will result in a car-body weight saving of 40-50%, fuel saving of 20-25%, and CO2 emission reduction of 28.6-35%, depending car models. The technology will be extended to other transportation sectors, such as aerospace, trucks, buses, surface and underground railways. This will put EU industry in the leading position for the lightweight, high-strength body part manufacturing technologies for transportation. Huge new business opportunities and new jobs will be created within the Europe.

Further details please contact Dr Nan Li of Imperial College London (n.li09@imperial.ac.uk)

1. This project has received funding from the European Union's Seventh Framework Programme for research, technological development and demonstration under grant agreement No. 604240.
2. HFQ® is a registered trademark of Impression Technologies Ltd in the UK, EU and USA



CBM's trail-blazing training project moves ever closer

Source: Confederation of British Metalforming – Metal Matters Issue 45

CBM members know that an ambitious training project is well underway in the Black Country, to tackle our industry's skills gaps.

The Elite Centre for Manufacturing Skills (ECMS) will deliver this £12m initiative via a hub at the University of Wolverhampton's new Springfield campus, and four 'spokes', one of which will be at the CBM's National Metalforming Centre (NMC) in West Bromwich.

The ECMS will deliver the training, starting this October, in partnership with the Automotive Trailblazer Council, of which both the CBM and the ECMS are members.

The Trailblazer concept may be new to companies, but it's a simple one. Each one includes a wide range of employers (at least ten) who work together to design new apprenticeship standards, for occupations within their sectors.

As a result, we can finally see the evolution of something we have demanded for decades; employer-led training, creating people with workplace skills relevant to business and

industry.

The standards are also devised to be suitable for organisations large and small, and both training providers and professional bodies are involved in their development.

Our most ambitious Trailblazer will deliver the next generation of process and tool design (PTD) engineers, who are responsible for designing and developing manufacturing process routes, with tooling for sheet-metal components, to meet quality, cost and delivery standards within a safe environment.

Each PTD engineer - working for an SME, or a Tier 1 or Tier 2 supplier - must be multi-skilled to meet the demands from in-house staff and their company's customers. It's a straightforward issue; no process, no tooling, no product, no business.

To deliver engineers with the correct skillset, the CBM has raised what is known as an Expression of Interest in establishing a Trailblazer Level 6 (degree course) apprenticeship training programme.

So far, a dozen CBM member companies have

offered this qualification their support, and I would expect that to increase in the coming months.

We have full details about the knowledge, skills and behaviours required for course entrants, and can supply them to members on request. As a degree level course, this training is expected to last three years.

The ECMS are also developing a Trailblazer Level 3 apprentice training for tool and die maintenance technicians, which will last two years. Both these courses will take place at a purpose-built training workshop at the NMC.

A third course, which would offer training led by CBM member firms covering the use of welding equipment and sheet-metal joining technology, will be held at Dudley College, another ECMS 'spoke'.

The precise syllabus is still being developed, according to employer needs, but it is likely that this training would be linked to an apprenticeship, and delivered via short one or two-day workshops.

Anyone wishing to learn more about the ECMS initiative, or the proposed courses, should contact me at the CBM on 07774 260126 or mail me via adrian.nicklin@thebcm.co.uk

Report on CBM Health & Safety Meeting February 2017

At a well attended meeting of the CBM H&S Group, a presentation was given on managing work-related road safety saying that it should be considered a business critical task, which not only ensures companies are compliant with health & safety legislation, but also has many business benefits too. One element of managing such an area is to engage in appropriate driver training. Delegates saw how training can make for better, safer drivers by honing speed management and observation, awareness and anticipation skills. Myths were dispelled about 'I'm OK with just one drink' as alcohol units with a focus on the 'morning after' were discussed. Also, there was a chance to become an accident investigator as real collisions were re-constructed to determine responsibility and 'avoidability' and support the notion that 95% of collisions have human error as the main culprit.

An HSE Specialist Inspector gave an update on the strategy " Helping Great Britain Work Well". This has six themes including "Ill Health"

and this subject continues to be a focus for proactive inspections. The purpose of this year's Inspection Programme is to target sectors where substances causing cancer and asthma are regularly used to ensure the risks are properly managed. From January 2017 inspectors will be targeting sites that carry out metal fabrication looking at the control of exposure to welding fume and metalworking fluids. Also catastrophic events such as last year's wood mill explosion will be investigated in depth.

In 2016 there were 144 deaths at work and 1.3 million reportable accidents.

Fines imposed by the courts following HSE prosecutions continue to grow due to new sentencing guide lines.

Other subjects covered in a very full agenda were accident statistic collection, the Manufacturing Growth Programme, environmental update and drug and alcohol abuse policies in the work place.



Baxi chooses AP&T

British Baxi, which manufactures boilers and water heaters, has chosen the new generation of automation equipment from AP&T. Among other things, the order comprises a new SpeedFeeder press robot and a control system upgrade for an existing AP&T press.

The equipment will be used to manufacture casings and chassis, and will be installed at Baxis' production facilities in Preston in Q1

2017. Baxi will thus be the first in the UK to use AP&T's new generation of SpeedFeeders, which are approximately 20 percent lighter and much more energy efficient and faster than previously.

"We have excellent experience with AP&T's solutions, and are certain that the new equipment will help us streamline our production further," says Paul Clayton, Baxi Engineering Support.



PJ Hare Ltd are leading UK manufacturers of hydraulic and hydro-pneumatic presses (1 to 400 tons), assembly tooling and integrated bespoke manufacturing solutions.

We design and manufacture a range of solutions which can offer speed, reliability and "zero defects" through 100% in process inspection and full poke yoke. Hare Tooling solutions integrate leading edge measuring and sensing components with system control to ensure that the highest quality is maintained.

P J Hare aim to exceed customer expectations and work with a diverse cross section of the World's leading automotive, aerospace and manufacturing companies.





The World's largest Servo Press

Nidec Arisa, based in Logrono, Spain. Part of the Nidec Press Technologies Group have designed and manufactured the world's largest servo press. The 4500T (45,000KN) press, along with the two per side Rolling Bolster, Transfer and Destacker systems left the factory during December 2016 and will be assembled and commissioned during January and February 2017 at the customer in Germany. Ready for hand over to the customer in March.

Nidec Arisa, have a long history. Founded more than 75 years ago the company has a long association with the automotive industry and counts many world recognised manufacturers as customers.

The "Line", when installed will be 37 metres in length, 20 metres wide and have a total height of 16 metres. Weighing more than 1,350t and

equipped with torque motors delivering 9MW of power. To make the utmost use of energy, the press is fitted with an Energy Management System, which regenerates and stores power, which then used as required to keep running cost to a minimum.

The Servo press will be fed by a Destacker unit which will load "Blanks" to a conveyor system. The conveyor moves the blanks through an oil-programmable band lubricator, which allows oil to be applied automatically. A state of the art transfer system moves the blanks through successive dies at high speed to achieve reliable and high performance production.

As oil prices have risen. Automotive manufactures have sought ways to supply more efficient and more economical vehicles, whilst meeting industry safety standards. This

has led to the use of lighter weight materials, Aluminium alloys and thinner section but higher tensile strength steels. These new materials have presented their own challenges. Challenges which are being answered by Nidec Press Technologies.

The installation will mark a first for Gestamp Automoción, one of the largest automotive suppliers worldwide. The Spanish company, with 100 production facilities around the world is leading the development and manufacture of components in high strength and light weight materials. From the outset, Gestamp Automocion realised the challenges faced and worked in collaboration with Nidec Arisa to develop this heavy tonnage and automated solution. Both companies, Gestamp with its powerful project management team in Bielefeld (Germany) and Nidec ARISA from Logroño (Spain), formulated a common idea, to develop and manufacture a very large servo press capable of delivering quality formed part using difficult to form materials.

Part of the development work undertaken by Nidec Arisa, involved simulation. Nidec Arisa have developed "Optiservo". Optiservo is simulation software which simulates the performance of the servomotors during forming and allows forming curves to be developed and optimised for production rates. This powerful and reliable software will prove invaluable to customers, as it allows stroke rates and cycles to be optimised without using the press, therefore maximising production and minimising set up time.

Nidec Arisa were aware the benefits of servo technology for presses back in the mid 2000's and commenced development work which culminated in the manufacture and sale of the first press which was a 400T in 2009. It has taken 7 years to go from 400T to 4500T. What will the future requirements be? Who knows is the answer. However, what we can say is Nidec Arisa will be leading the way!



Institution of MECHANICAL ENGINEERS

Improving the world through engineering



ISME Thank our event sponsors



Institute of Sheet Metal Engineering

Presents

The 2017 ISME

Sheet Metal Technology Competition

FOR APPRENTICES & TRAINEE'S

Judgement Day to be held at:

**Coventry Transport Museum
Millennium Place,
Hales St,
Coventry CV1 1JD**

On Thursday 15th June 2017



ISME Forward

First of all we want to thank Coventry Transport Museum for hosting the ISME 2017 Competition.

The Institute of Sheet Metal Engineering is a learned body with individual membership open to those employed in the sheet metal and associated industries. It was formed over 60 years ago to promote the science of working and using sheet metal and to provide opportunities for people to exchange ideas and information. We also encourage the development of members by providing networking opportunities and creating an institute that people in the industry aspire to join. The encouragement of the development of sheet metal working skills in young people through

the annual Sheet Metal Skills Competition is very important to the Institute.

The Institute has a student grade membership of £20/year for which you will receive copies of the ISME Journal, Oracle which keeps members up to date with the latest developments and events in the Sheet Metal Industry. Students Joining on the day of the skills competition get the first years membership free. For details of membership please go to; www.isme.btck.co.uk

OFFLOADING EXHIBITS & PARKING

To offload go to the rear of the museum, then Pay & Display Parking opposite in Silver Street, off Bishop Street. CV1 1JN.

About: Coventry Transport Museum

Coventry Transport Museum opened in 1980, after it became clear that the road transport collection was outgrowing the space it occupied in the Herbert Art Gallery & Museum.

The Museum's current collection of vehicles is acknowledged as being one of the finest in the world, and the largest in public ownership.

The first exhibits were acquired in 1937 when Samuel Bartleet gifted the City of Coventry his own private collection of cycles. The first motor cars were added to the collection in 1952, and the collection has continued to grow ever since.

The first major public exhibitions began in 1960

with the official opening of the Herbert Art Gallery and Museum. As the transport collection grew, the vehicles were housed in a number of local sites, eventually settling at their present location in 1980.

The Museum's collection consists of motor cars, commercial vehicles, cycles and motorcycles. In addition, extensive collections of automobilia, books, photographs and a wealth of other archive material is held and conserved at the Coventry History Centre at the Herbert Art Gallery & Museum. Most of the collection exists through the outstanding generosity of individual donors.



Judgement Day Itinerary

9.30am	ISME Judges arrive at 9.30 for registration and competition briefing. Tea/Coffee available.
10.30am - 11.00am	Apprentices and trainers with exhibits arrive and register. Tea/Coffee and light refreshments available.
11.30am	Apprentices and trainers are given a welcome message from ISME President and Venue Staff.
11.30am	Judging Commences with only authorised ISME members in display area.
12.30pm	Buffet Lunch to be served
1.30pm - 3pm	After Lunch free time continues
2.30pm	ISME President and ISME Events Officer to meet & greet additional Guests. Tea & coffee available.
3.15pm	Presentation commences. ISME President welcomes guests and thanks sponsors. Present certificates and Prizes. Closed by ISME Events officer. Photo's. Estimated finish time 4.00pm



The ISME Competition Detail

The **Sheet Metal Skills Competition** provides great opportunity for young apprentices & trainee's to measure their skills against others in the sheet metal and pressed metal industry. To be the overall Winner of the ISME Trophy you must enter one of the test pieces and also provide an open class exhibit.

- All the drawings are on the ISME website (www.isme.btck.co.uk) along with the marking assessment forms.
- The entry should include a written account (Plan) on how and why the various making techniques were chosen and applied.
- The types of machines and tools used with H&S consideration must clearly be stated and if you wish include photo's.
- Every entry should include a self-handwritten 200 words about yourself.
- We expect the competitor to self-validate Test Piece dimensions and record on the marking Assessment Form being part of the Written Account.
- The Test Pieces will be judged as per the Marking Assessment Form. The Open Class work piece will be judged as per the Marking Assessment Form.

Please Note

- The item entered should reflect the training level of the Competitor.
- Their trainer must confirm the competitor's level on the entry form.
- The age of the competitor must be stated on the entry form.
- All entries should be clearly labelled with competitor's name and DOB preferred on inside of item.
- ALL COMPETITORS WILL RECEIVE FREE OF CHARGE 1 YEAR ISME MEMBERSHIP

To enter the competition, please complete the Entry Form.

Please complete an entry form for each competitor.

Please photocopy the form complete and return to ISME by post or scan and email details on form.

Any queries please call 07774 260126

Category 1 Test Piece

Wall Vent

- Year 1 Apprentices & Trainee's

- Test Piece make Winner Receives Cash Prize
- Test Piece written Document Winner Receives Cash Prize



Please note: Modified drawing available at www.isme.btck.co.uk

Category 2 Test Piece

Ducting

- Year 2/3/4 Apprentices & Trainee's

- Test Piece make Winner Receives Cash Prize
- Test Piece written Document Winner Receives Cash Prize
- This component can be made to the 2D dimensioned drawing.



Please note: Modified drawing available at www.isme.btck.co.uk

Category 3 Test Piece

Hinged Clasp

Year 2/3/4 Apprentices & Trainee's

- Test Piece make Winner Receives Cash Prize
- Test Piece written Document Winner Receives Cash Prize

This test piece is aimed towards Apprentices who are training to be toolmakers. It may be necessary to make simple tools to produce certain features on the component. Please provide photos evidence with your written documentation.

Besides making the Hinged Clasp Why not make the Checking fixture? Check dimensions identified on Dimensional check sheet.

Best Checking Fixture make Winner Receives Cash Prize

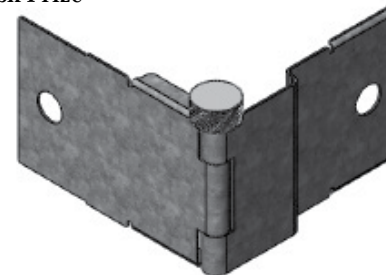

Basic Checking fixture Drawings available
On request for design ideas.

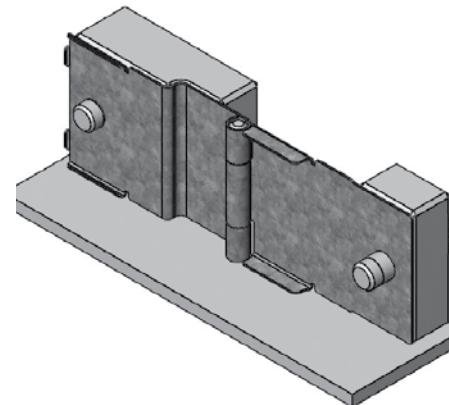

This component can be made to the 2D drawing or if requested we can provide a 3D CAD model (email adriannicklin@btinternet.com).



Example from previous Competition

Category 4 Open Class

Open to all Apprentices & Trainee's

Competitors to make a metal work piece of your choice

- Judged Winner Receives Cash Prize
- Written Document Winner Receives Cash Prize

Judging Criteria

- See Marking & Assessment Form



Example from previous Competition



**Institute of Sheet Metal
Engineering**

Institute of Sheet Metal Engineering
ISME Events
14 Swynnerton Drive
Essington
Wolverhampton
WV11 2TB
Phone: 07774 260126
Email: adriannicklin@btinternet.com

Sheet Metal Skills Competition

Competition Judging to be held at
Coventry Transport Museum, Millennium Place, Hales St, Coventry CV1 1JD

on
Thursday 15th June 2017

ENTRY FORM

Please complete and return one form for each entrant. Format for the day will be confirmed nearer the time.

Entrant's Name: _____

Home Address: _____

Date of Birth: _____ Age at 1st January 2017 _____

Email: _____

Categories entered (Tick boxes please)

Category 1 Wall Vent year 1 trainees only

Category 2 Ducting year 2, 3 & 4 trainees

Category 3 Clasp year 2, 3 & 4 trainees

Category 4 Open Class

I confirm the trainee in currently year level

Signed

Training Manager

Training Establishment / Employer _____

Contact Name at _____

Training Establishment / Employer _____

Address: _____

Telephone: _____ Fax: _____

e-mail: _____

Please return this entry form ASAP to: Institute of Sheet Metal Engineering at the address above

There is a weblink to a pdf of this document, go to www.isme.btck.co.uk



Originality Open Class winner Andrew Neal



Clasp Test Piece Written Winner Scott Jay



Clasp Checking Fixture winner Ricki Riaz



Clasp Test Piece Make Winner Kieren Coles



Ducting Test Piece Winner Ben Lang



ISME Trophy Overall Competition Winner Ben Lang



John Davies Open Class Award Winner Stephen Livick



Overall Winner Ben Lang Babcock



Ted Rosmarin Award winner Andrew Neal



Wall Vent Make Winner Terry Yates

Pictures from **2016** competition



Site Service

Breakdown repairs plus scheduled maintenance

Spare Parts

To original specifications for all makes of presses

Power Press Inspections

Compliance with HSE regulations

Press Refurbishing

To customer requirements

Hydraulic Presses

Bushes, seals, press rams refurbished

Machine Relocation

Complete 'turnkey' service

Electrical & Control Systems

Service, safety, repairs, replacement panels, full system upgrades

Sub-contract Machining

Single component to batch manufacturing

Tel: 0121 520 4320 E-mail: admin@mpps.co.uk

www.mpps.co.uk